

VARIATION OF MITOCHONDRIAL CONTROL REGION SEQUENCES OF STELLER SEA LIONS: THE THREE-STOCK HYPOTHESIS

ALYSON R. BAKER, THOMAS R. LOUGHLIN, VLADIMIR BURKANOV, COLE W. MATSON, ROBERT G. TRUJILLO, DONALD G. CALKINS, JEFFREY K. WICKLIFFE, AND JOHN W. BICKHAM*

Department of Wildlife and Fisheries Sciences, Texas A&M University, College Station, TX 77843-2258, USA (ARB, CWM, RGT, JW)

National Marine Mammal Laboratory, 7600 Sand Point Way NE, Seattle, WA 98115, USA (TRL)

Natural Resources Consultants, c/o National Marine Mammal Laboratory, 7600 Sand Point Way NE, Seattle, WA 98115, USA (VB)

Kamchatka Branch of the Pacific Institute of Geography Russian Academy of Sciences, 19A Prospekt Rybakov, Petropavlovsk-Kamchatsky, 683024, Russia (VB)

Alaska Sea Life Center, 301 Railway Avenue, Box 1329, Seward, AK 99664, USA (DGC)

Department of Preventive Medicine and Community Health, University of Texas Medical Branch, 301 University Boulevard, Galveston, TX 77555-1110, USA (JKW)

Sequence variation in the mitochondrial DNA (mtDNA) control region was analyzed from 1,568 individuals representing nearly every rookery ($n = 50$) at which Steller sea lions (*Eumetopias jubatus*) are known to breed in significant numbers. Rookeries were grouped into regions and regions into stocks to examine structure at different spatial scales. Haplotype diversity ($H = 0.9164 \pm 0.0035$) was high and nucleotide diversity ($\pi = 0.00967 \pm 0.00586$) was moderate. No evidence was observed for significant genetic bottleneck effects. Previous studies of mtDNA recognized 2 stocks (eastern and western) and suggested the presence of 2 groups within the western stock. In this study, significant ($P < 0.05$) divergence of eastern stock (southeastern Alaska to California) animals from western stock animals was supported in analyses at all spatial scales. Likewise, rookeries and regions from Asia were found to be significantly different from all other western stock rookeries. This was most clearly demonstrated in regional comparisons. The Commander Islands rookery clearly associates with Alaskan western stock rookeries, not with the Asian rookeries. Within each of the 3 stocks there is significant isolation by distance among rookeries. This relationship does not hold for interstock comparisons, indicating that there are important barriers to gene flow among stocks. We recommend that the western stock be partitioned west of the Commander Islands, yielding a western stock that ranges from Prince William Sound west to the Commander Islands, and an Asian stock including rookeries from the Kamchatka Peninsula, Kuril Islands, and Sea of Okhotsk. The eastern stock remains unchanged and includes rookeries from southeastern Alaska through California.

Key words: *Eumetopias jubatus*, mitochondrial DNA, phylogeography, Steller sea lion, stock structure

Steller's sea lion (*Eumetopias jubatus*) was described by George Wilhelm Steller in 1742. This species is the largest member of the family Otariidae (Allen 1870; Gentry and Withrow 1986) and is endemic to the North Pacific Ocean. Rookeries are distributed along an arc following the edge of the North Pacific Ocean. Distribution of the rookeries ranges from

the west coast of the continental United States (California and Oregon), north along the Canadian and Alaskan coasts, west across the Gulf of Alaska, Aleutian Islands, and Commander Islands, along the east coast of the Kamchatka Peninsula, within the Sea of Okhotsk, and southwest throughout the Kuril Islands (Fig. 1).

Although the total population of Steller sea lions was believed to number between 240,000 and 300,000 in the late 1950s and early 1960s (Kenyon and Rice 1961) and between 245,000 and 290,000 during the 1980s (Loughlin et al. 1984), their populations experienced a significant decline in the years that followed, with only 116,000 present in 1989 (Loughlin

* Correspondent: j-bickham@tamu.edu

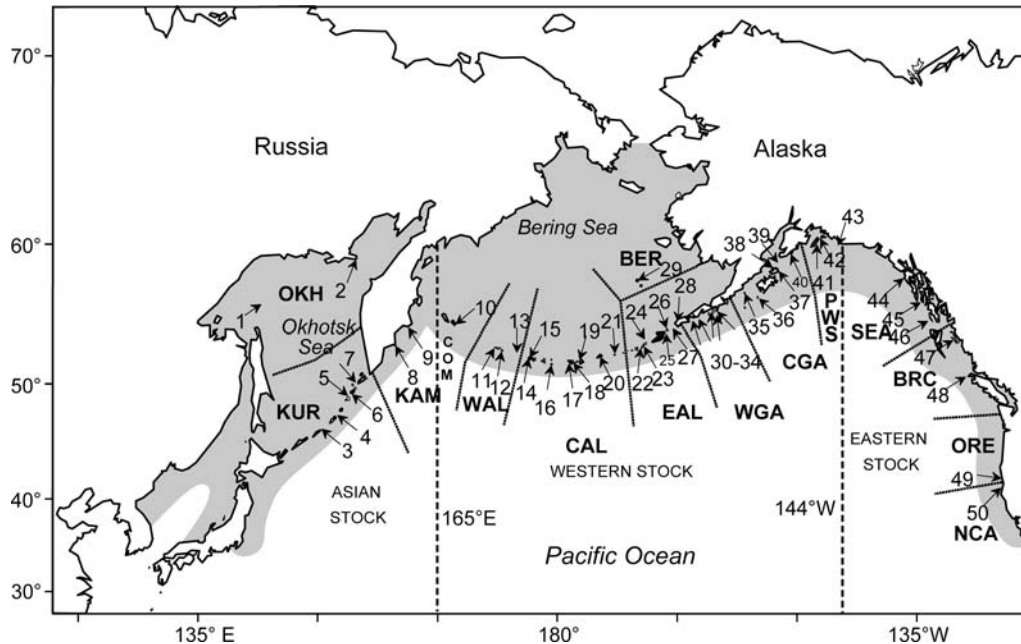

FIG. 1.—Map of the North Pacific Ocean and Bering Sea showing localities used in this study. Shaded area represents range of Steller sea lions. Rookery locations are indicated by numbered arrows; rookery numbers are given in Appendix I. Regional designations: Sea of Okhotsk = OKH, Kuril Islands = KUR, Kamchatka Peninsula = KAM, Commander Islands = COM, western Aleutian Islands = WAL, central Aleutian Islands = CAL, eastern Aleutian Islands = EAL, Bering Sea = BER, western Gulf of Alaska = WGA, central Gulf of Alaska = CGA, Prince William Sound = PWS, southeastern Alaska = SEA, British Columbia = BRC, Oregon = ORE, northern California = NCA.

et al. 1992). Likewise, the western United States stock population was estimated at 177,000 in the 1960s but numbered only 33,600 in 1994 (National Marine Mammal Laboratory 1995). Such extreme losses attracted worldwide attention and led to the Steller sea lion being listed as threatened under the United States Endangered Species Act in 1990.

The ultimate reason for the population decline is unknown, but a number of potential factors have been tested over the years. These factors include relocation, short-term environmental fluctuations, human exploitation, pollution, disease, competition with commercial fisheries, predation, and major oceanic regime shifts (Loughlin 1998; Loughlin et al. 1992). However, no single factor can be clearly shown to account for all aspects of the decline. York (1994) suggested that a 10–20% increase in juvenile mortality could account for the degree of decline noted for Steller sea lions. Although this discovery is critical, decreased juvenile mortality represents only a proximate cause. It seems likely that the reasons for the decline are multifactorial and they may never be completely understood.

After listing of the Steller sea lion as threatened in 1990, a number of studies attempted to clarify not only the cause(s) of the decline but also to describe basic aspects of Steller sea lion biology. Of critical importance to the conservation of the species is an understanding of population structure and patterns of gene flow. Several population genetic studies have addressed genetic diversity and the evolutionary history of the species (Bickham et al. 1996, 1998a, 1998b; Trujillo et al. 2004). In contrast to a previous biochemical study that indicated little to no genetic diversity in Steller sea lion populations (Lidicker et al. 1981), Bickham et al. (1996) reported high variability

for mitochondrial DNA (mtDNA) control region sequences. Significant genetic divergence was observed between animals sampled from rookeries in the Commander and Aleutian islands and the Gulf of Alaska and those from southeastern Alaska through Oregon (regions west and east, respectively, of Cape Suckling, Alaska; longitude 144°W). Bickham et al. (1996) suggested that the overall population be divided into 2 management units, the western and eastern stocks. Further genetic research, as well as accumulated information regarding Steller sea lion distribution, phenotypic variation, and population response, supported the recognition of 2 stocks (Bickham et al. 1998a, 1998b; Loughlin 1997). The western stock, which is continuing to decline, was listed as endangered in 1997. The current western stock population of Alaska comprises approximately 26,000 nonpup animals (Sease and Gudmundson 2002) and stock losses are estimated at 5% per year (Sease et al. 2001). At this rate of decline, less than 1,000 animals will comprise the population west of Cape Suckling, Alaska, to the westernmost tip of the Aleutian Islands in the year 2020 (Loughlin and York 2000). In contrast, eastern stock numbers have increased from 13,000–15,000 during the period 1965–1985 to 19,000 in 1995. However, this stock remains listed as threatened.

Still further tests are needed to define population structure at the far western limits of the Steller sea lion distribution. Previous research has indicated that animals sampled from Russian rookeries in the Sea of Okhotsk, Kuril Islands, Kamchatka Peninsula, and Commander Islands were genetically distinct from other western stock sea lions (Bickham et al. 1998b; Trujillo et al. 2004). However, sample sizes were

generally inadequate to conclusively resolve western stock substructure.

This study includes mtDNA sequence data for 1,568 Steller sea lions taken from 50 rookeries from throughout the range of the species. Nearly every locality at which this species is known to breed in significant numbers was sampled. These samples represent approximately 2.8% of the 53,400 extant nonpup population estimated from range-wide counts made during the years 2000–2002. This paper specifically focuses on a population genetic assessment of mtDNA variability and stock structure in the western range of the Steller sea lion.

MATERIALS AND METHODS

Study area and sample size.—Tissue samples obtained from rear flipper punches and preserved in saturated NaCl with 20% dimethylsulfoxide were initially stored at room temperature (Amos and Hoelzel 1991) and later archived at -80°C . All samples are from pups taken from their natal rookeries. Tissue voucher samples are archived in the Texas Cooperative Wildlife Collection, Texas A&M University. The total sample size for this study was $n = 1,568$ and the numbers of animals sampled per rookery, region, and stock are given in Appendix I. The study includes new data for 1,176 animals and we also include 392 animals reported previously (Bickham et al. 1996, 1998b). All specimens examined were humanely treated according to guidelines of the American Society of Mammalogists (Animal Care and Use Committee 1998) and were collected under Marine Mammal Protection Act permit 782-1532-02.

Molecular methods.—Total genomic DNA was extracted by using established organic methods (Maniatis et al. 1982). Primers designed by LGL Ecological Genetics, Inc. (Bryan, Texas) were used for amplification of a 450-base pair (bp) region of the mitochondrial control region. These primers are LGL 283 (5'-TACACTGGTCTTC TAAACC-3') and LGL 1115 (5'-ATGACCCTGAAGAARGAAC CAG-3'). We sequenced a 238-bp segment of the control region by using the LGL 1115 primer as the sequencing primer as in previously described methods (Bickham et al. 1996). The small region was selected because it is highly variable and data can be obtained from a single sequence analysis per animal. The length of the segment is bound by the primer (downstream) and by a poly-A region upstream.

Statistical methods.—The proportion of nucleotide sites that differ (p_n) within the 238-bp sequence was calculated by dividing the number of variable sites by the total number of nucleotides (Hedrick 2000). Haplotype (gene) diversity, which is equivalent to heterozygosity of a nuclear locus and ranges from 0 to 1 (H —Nei 1987), and nucleotide diversity, which is the average proportion of nucleotide difference between all possible pairs of sequences in the population (π —Nei 1987), were determined for regional population groupings and stocks by using ARLEQUIN (<http://anthro.unige.ch/arlequin>, last accessed 26 August 2005).

Exact tests for significant population differentiation for all pairwise comparisons using rookeries with $n \geq 10$, regions, and stocks were conducted in ARLEQUIN. This test is analogous to Fisher's exact test on a 2×2 contingency table but extended to an $r \times k$ contingency table (Raymond and Rousset 1995). Two separate measures of the degree of genetic divergence occurring between subdivisions of a population, conventional F - (Wright 1951) and Φ -statistics (Excoffier et al. 1992), were estimated by using ARLEQUIN. F_{st} estimates infer population structure by using only haplotype frequencies, whereas Φ_{st} estimates incorporate both haplotype frequencies and the number of variable nucleotides observed between haplotypes. The F - and Φ -

statistics therefore are referred to as frequency-based and genetic-based parameters, respectively (Westlake and O'Corry-Crowe 2002). The Tamura and Nei (1993) measure of evolutionary distance between nucleotide sequences, which was specifically developed from mtDNA control region data, was used to calculate the approximate degree of differentiation between haplotypes before conducting Φ_{st} analyses. Probabilities for all measures of genetic distance were estimated by using 10,000 randomizations of the original data set; this represents a 10-fold increase over the minimum number of permutations required to obtain an accurate probability estimate. In addition, a transformation (Slatkin 1995) was applied when calculating both F_{st} and Φ_{st} estimates to linearize population divergence time and distance. The results are matrices of genetic distances consisting of positive values only. Neighbor-joining trees were generated by using the matrices of genetic distances calculated for all pairwise comparisons at the rookery, region, and stock levels (for both the F_{st} and Φ_{st} methods) by using PAUP* 4.0 (Swofford 1998). All trees were constructed by using midpoint rooting.

Regressions of genetic distance (F_{st} and Φ_{st}) on geographic distance and correlations between genetic and geographic distances among rookeries were computed by using the R Package, version 4.0 (<http://www.bio.umontreal.ca/legendre/index.html>, last accessed 26 August 2005). Matrices of geographic distances were constructed by using surface distances for all possible pairwise comparisons among the 43 rookeries represented by a sample size of $n \geq 10$. The R Package was then used to test the null hypothesis of independence between genetic and geographic distances by estimating departures from randomness using a variation of the Z -statistic (Mantel 1967). Significance of the test statistic was then estimated by using 99,999 permutations of the data.

Lastly, a maximum-likelihood approach was applied at the stock level to estimate the number of effective migrants per generation ($N_f m$, where N_f represents the number of effectively breeding females and m is the migration rate—Hartl and Clark 1997). Original estimates of $N_f m$ were obtained by analyzing 2 replicates by using default settings from MIGRATE (<http://evolution.genetics.washington.edu/lamar.html>, downloaded 7 June 2003), which calculate initial parameter estimates from F_{st} values. The average of the 2 estimates was then calculated for each parameter, and these values replaced F_{st} estimates in following analyses. The program was then run until equivalent estimates were obtained between replicates. The length of analyses (number of short and long chains and length of chains) was generally increased to ensure a more accurate estimation of population parameters.

RESULTS

General diversity measures.—A 238-bp region of the mitochondrial control region was analyzed for sequence variation. There were 46 polymorphic sites, all of which were substitutions (40 transitions and 6 transversions). The proportion of polymorphic sites (p_n) equaled 46 of 238, or 0.193. Haplotype diversity was high ($H = 0.916 \pm 0.004$), as expected because of the rapid evolution and divergence of the mtDNA control region. Nucleotide diversity was only moderate ($\pi = 0.0097 \pm 0.0059$), because nearly all haplotypes differed by a single substitution event. Haplotype and nucleotide diversities for regions and stocks are provided in Table 1. One hundred twenty-one haplotypes were observed, including 46 new haplotypes (AAAA-NNNN, PPPP-ZZZZ, AAAAA, QQQQQ-ZZZZZ, AAAAAA-JJJJJ). The sequences were deposited in

TABLE 1.—Haplotype (H) and nucleotide (π) diversities ($\pm SD$) for regional and stock groupings of Steller sea lions, based on mitochondrial DNA control region sequences. Regions and stocks are as in Fig. 1.

	H	π
Sea of Okhotsk	0.815 \pm 0.027	0.0068 \pm 0.0045
Kuril Islands	0.894 \pm 0.013	0.0078 \pm 0.0050
Kamchatka Peninsula	0.867 \pm 0.031	0.0076 \pm 0.0049
Commander Islands	0.900 \pm 0.014	0.0099 \pm 0.0060
Western Aleutian Islands	0.895 \pm 0.020	0.0087 \pm 0.0055
Central Aleutian Islands	0.850 \pm 0.015	0.0086 \pm 0.0054
Eastern Aleutian Islands	0.876 \pm 0.014	0.0093 \pm 0.0057
Bering Sea	0.866 \pm 0.052	0.0092 \pm 0.0059
Western Gulf of Alaska	0.856 \pm 0.019	0.0081 \pm 0.0051
Central Gulf of Alaska	0.828 \pm 0.026	0.0082 \pm 0.0052
Prince William Sound	0.871 \pm 0.019	0.0091 \pm 0.0056
Southeastern Alaska	0.931 \pm 0.014	0.0122 \pm 0.0072
British Columbia	0.901 \pm 0.041	0.0101 \pm 0.0064
Oregon	0.909 \pm 0.017	0.0111 \pm 0.0067
Northern California	0.867 \pm 0.107	0.0090 \pm 0.0062
Asian stock	0.874 \pm 0.012	0.0076 \pm 0.0048
Western stock	0.872 \pm 0.007	0.0090 \pm 0.0055
Eastern stock	0.922 \pm 0.010	0.0113 \pm 0.0067
Overall	0.916 \pm 0.004	0.0097 \pm 0.0059

GenBank under accession numbers AY340876–AY340937. Haplotypes S and BB were by far the most common haplotypes detected, representing 18.2% and 15.9% of the sample, respectively. Frequencies of all other haplotypes were less than 10%. Thus, an L-shaped distribution was obtained when haplotype number was plotted against haplotype frequency class. Many haplotypes were restricted to certain regions. For

instance, LLL was found only in Asia, E was restricted mainly to the western stock, H was only found in eastern stock rookeries, whereas BB was distributed range-wide (Fig. 2). A table of haplotype frequencies for each rookery or region is available upon request.

Measures of genetic distance.—Haplotype data were used to perform range-wide analyses of population structure. Exact tests of population subdivision, Slatkin’s linearized F -statistics, and Φ -statistics were calculated for all pairwise comparisons at rookery, region, and stock levels. Exact tests of population differentiation yielded largely significant values at all levels of comparisons. The numbers of significant pairwise comparisons ($P \leq 0.05$) were 537 of 903 comparisons of rookeries (59%), 87 of 105 comparisons of regions (83%), and 3 of 3 comparisons of stocks (100%).

F - and Φ -statistics were calculated for all pairwise comparisons. Among the 43 rookeries with $n \geq 10$, the numbers of significant pairwise comparisons ($P \leq 0.05$) for F_{st} estimates were 468 of 903 comparisons (52%), and for Φ_{st} there were 549 of 903 comparisons (61%). A neighbor-joining tree was constructed from the F_{st} distance matrix (Fig. 3A) by using only the 43 rookeries with $n \geq 10$ (i.e., excluding Amak Island, Cape St. Elias, Chernabura Island, Chiswell Island, Latax Rocks, Ulak Island, and The Whaleback). The resulting tree exhibited some of the expected groupings. For instance, the eastern stock rookeries located along the coasts of British Columbia, Oregon, and northern California formed a lineage distinct from all western stock rookeries. Rookeries from southeastern Alaska (White Sisters Islands, Hazy Islands, and Forester Islands) also were expected to cluster with the eastern stock. Instead, 2 of the southeastern Alaska rookeries (White

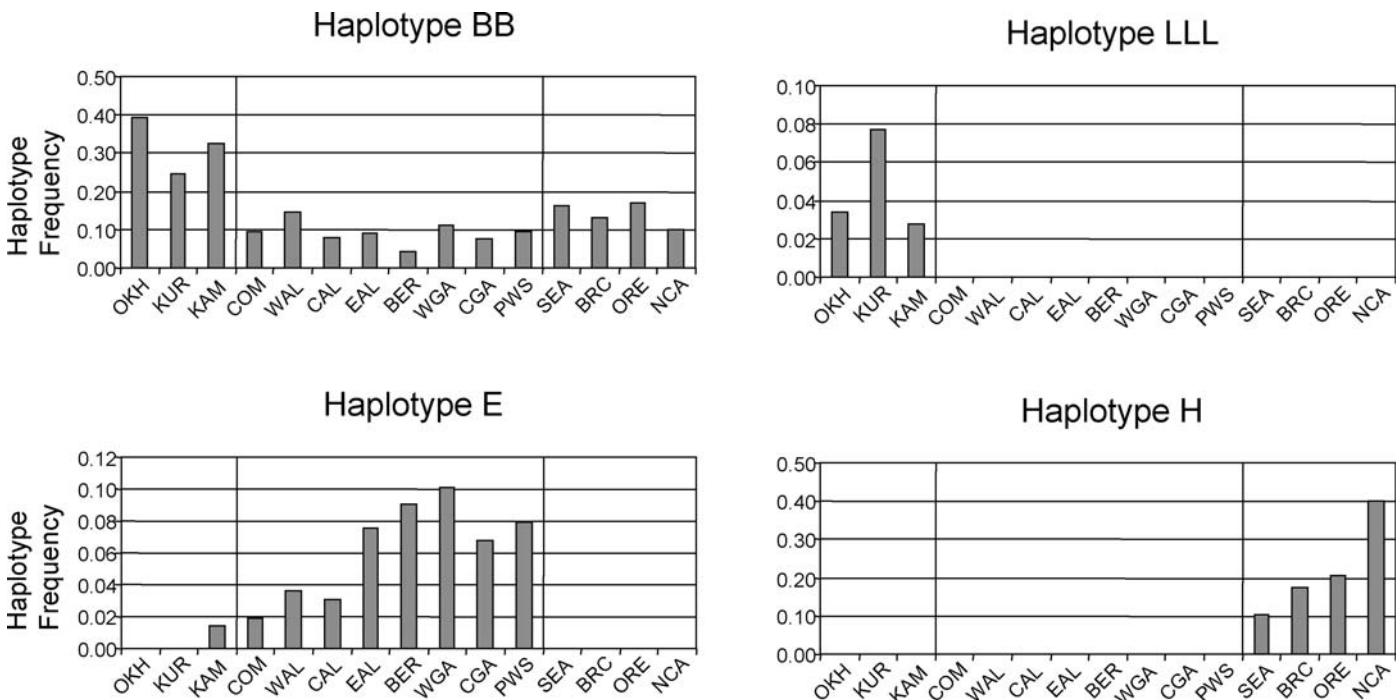

FIG. 2.—Distribution of 4 common control region haplotypes in Steller sea lions (BB, LLL, E, and H) at the regional level. Regional codes are as in Fig. 1. A vertical bar separates each stock.

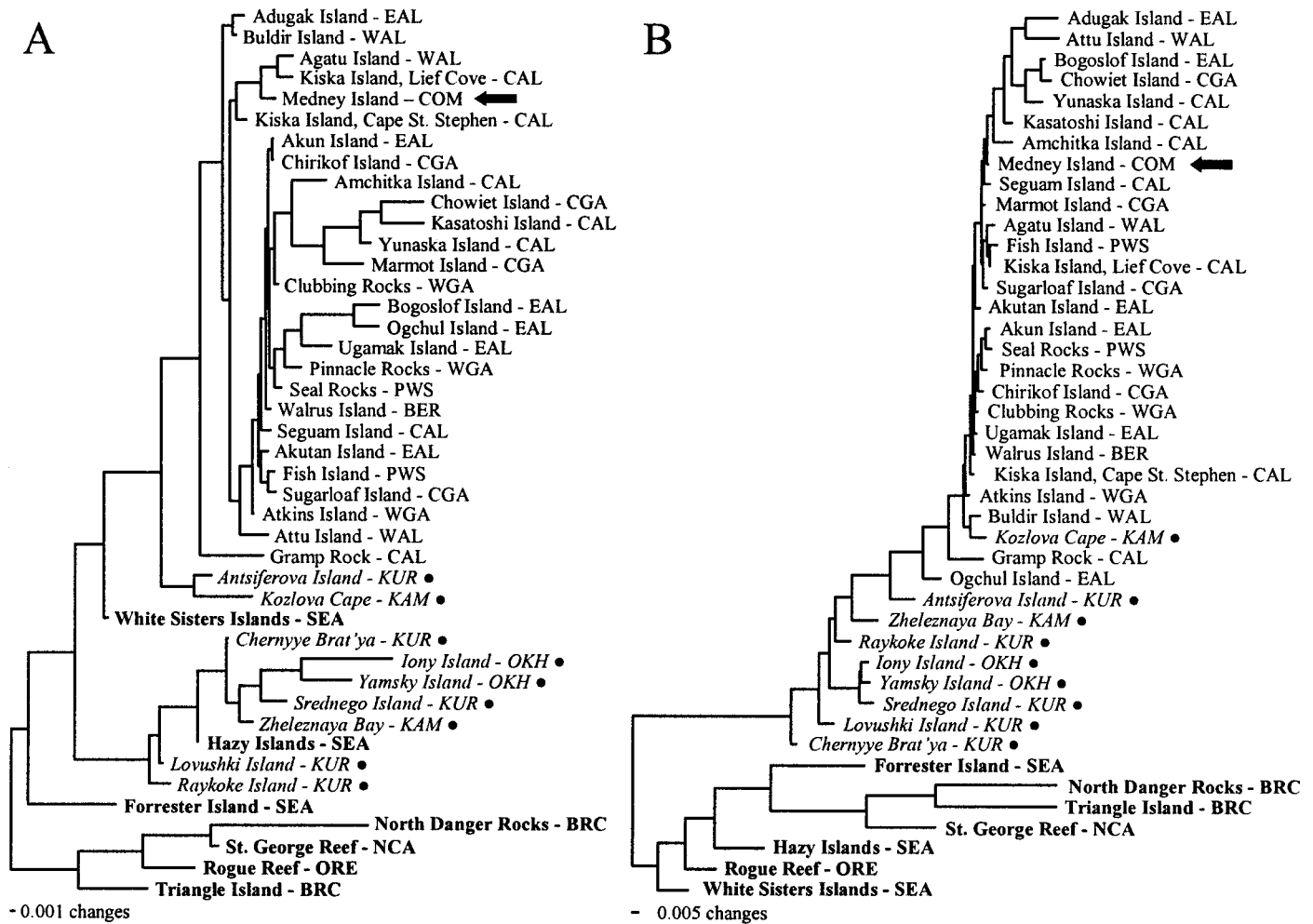

FIG. 3.—Neighbor-joining tree based on Slatkin’s (1995) linearized A) F_{st} - and B) Φ_{st} -statistics at the rookery level. Note that the Medny Island rookery (Commander Islands) is nested well within the western stock (denoted with an arrow). Western stock rookeries are in normal font, eastern stock rookeries are bold, and Asian stock rookeries are in italics and denoted with a “•”. Regional codes are as in Fig. 1.

Sisters Island and Hazy Island) were nested within the Asian stock (Sea of Okhotsk, Kuril Islands, and Kamchatka Peninsula). Many of the eastern stock rookeries are represented by relatively few samples. These small sample sizes may account for the failure of the southeastern Alaska rookeries to group with the remaining eastern stock rookeries.

The majority of Asian rookeries comprise a cluster with Hazy Islands (southeastern Alaska) located near the base of the branch leading to the western stock rookeries. This branch does not include Antsiferova Island (Kuril Islands) and Kozlova Cape (Kamchatka Peninsula), which form a branch placed sister to rookeries belonging to the remaining western stock rookeries. Medny Island, the only rookery from the Commander Islands, was placed among Alaskan western stock rookeries. All western stock rookeries, plus Medny Island, comprise a single clade (Fig. 3A).

The neighbor-joining tree constructed from the pairwise distance matrix of Φ_{st} estimates (Fig. 3B) indicated strong divergence of eastern stock rookeries. Rookeries belonging to the western stock formed a single branch, with Asian rookeries occupying the most basal positions. Again, Medny

Island (Commander Islands) was located well within the lineage among Alaskan western stock rookeries. Kozlova Cape also was nested among Alaskan western stock rookeries but was separated from the other Asian rookeries only by Gramp Rocks and Ogchul Island (both Central Aleutian Islands), both of which are represented by small sample sizes ($n = 10$).

Next, both F - and Φ -statistics were calculated for all pairwise comparisons of the 15 regions (Table 2). Among these, 79% (83/105) of F_{st} and 72% (76/105) of Φ_{st} comparisons were significant ($P \leq 0.05$). For both F - and Φ -statistics, southeastern Alaska, British Columbia, Oregon, and northern California were shown to be significantly different from all other non-eastern stock regions. The Kuril Islands, Sea of Okhotsk, and Kamchatka Peninsula also were significantly different from nearly all other regions, whereas the Commander Islands were not significantly different from the nearby western and central Aleutian Islands.

As with the rookeries, neighbor-joining trees were constructed from the regional pairwise distance matrices generated in ARLEQUIN. The tree constructed from the matrix of

TABLE 2.—Slatkin’s (1995) linearized F_{st} and Φ_{st} -statistics (F_{st} below diagonal; Φ_{st} above diagonal) for all pairwise regional comparisons for Steller sea lion mitochondrial DNA haplotypes. Significant values ($P \leq 0.05$) are in bold. Regional designations are as in Fig. 1.

	OKH	KUR	KAM	COM	WAL	CAL	EAL	BER	WGA	CGA	PWS	SEA	BRC	ORE	NCA
OKH	—	0.03	0.04	0.13	0.12	0.13	0.11	0.14	0.13	0.15	0.14	0.26	0.48	0.26	0.39
KUR	0.02	—	0.05	0.11	0.10	0.11	0.08	0.10	0.08	0.12	0.09	0.19	0.35	0.20	0.26
KAM	0.02	0.02	—	0.03	0.01	0.04	0.03	0.02	0.04	0.05	0.04	0.25	0.48	0.25	0.36
COM	0.11	0.06	0.04	—	0.00	0.00	0.01	0.01	0.03	0.01	0.02	0.30	0.48	0.31	0.37
WAL	0.10	0.05	0.02	0.00	—	0.00	0.00	0.00	0.01	0.00	0.01	0.27	0.50	0.29	0.38
CAL	0.15	0.09	0.07	0.00	0.00	—	0.01	0.00	0.02	0.01	0.01	0.33	0.53	0.34	0.41
EAL	0.13	0.07	0.06	0.02	0.01	0.01	—	0.00	0.00	0.00	0.01	0.28	0.47	0.29	0.35
BER	0.17	0.09	0.08	0.02	0.01	0.01	0.00	—	0.00	0.00	0.00	0.24	0.46	0.26	0.35
WGA	0.13	0.07	0.06	0.02	0.01	0.01	0.00	0.00	—	0.00	0.01	0.27	0.50	0.29	0.38
CGA	0.18	0.10	0.09	0.03	0.02	0.01	0.00	0.00	0.01	—	0.00	0.33	0.57	0.34	0.44
PWS	0.13	0.07	0.07	0.02	0.01	0.01	0.00	0.00	0.00	0.00	—	0.26	0.45	0.27	0.32
SEA	0.06	0.02	0.04	0.05	0.05	0.08	0.07	0.08	0.06	0.10	0.07	—	0.01	0.00	0.00
BRC	0.11	0.07	0.08	0.09	0.09	0.13	0.11	0.12	0.12	0.15	0.11	0.02	—	0.01	0.00
ORE	0.07	0.05	0.06	0.08	0.08	0.12	0.10	0.11	0.11	0.14	0.10	0.01	0.02	—	0.00
NCA	0.14	0.09	0.11	0.11	0.11	0.15	0.13	0.14	0.14	0.17	0.13	0.01	0.02	0.00	—

F -statistics (Fig. 4A) indicated strong differentiation of regions from the eastern stock. The Asian regions, Kamchatka Peninsula, Kuril Islands, and Sea of Okhotsk formed a branch that was placed sister to a clustering of western stock regions. Once again, Commander Islands was clustered among western stock regions rather than among Asian regions. The western stock regions east of the central Aleutian Islands (eastern Aleutian Islands, Bering Sea, western Gulf of Alaska, central Gulf of Alaska, and Prince William Sound) formed a clade with very short branch lengths, suggesting that these regions are not

well differentiated. The neighbor-joining tree constructed from Φ -statistics (Fig. 4B) for the region level also indicated strong genetic differentiation of the eastern stock regions. The Asian regions, Kamchatka Peninsula, Kuril Islands, and Sea of Okhotsk were shown to be closely related, although they did not form a separate branch. The western stock regions and the Commander Islands formed a clade that was sister to the Kamchatka Peninsula. Branch lengths in the western stock clade were all quite short, indicating little genetic differentiation among western stock regions.

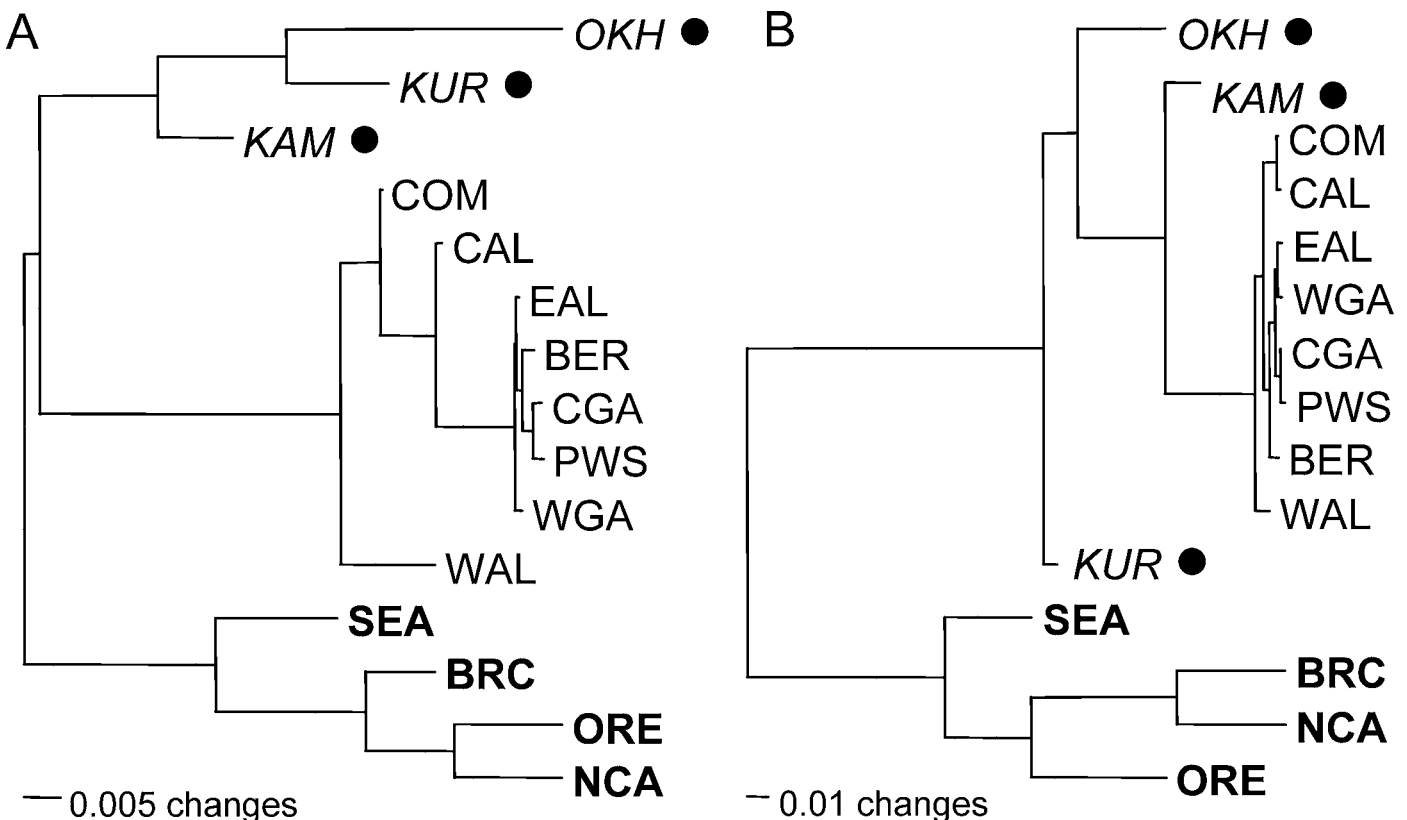

FIG. 4.—Neighbor-joining tree based on A) Slatkin’s (1995) linearized F_{st} and B) Φ_{st} -statistics at the regional level. Western stock rookeries are in normal font, eastern stock rookeries are bold, and Asian stock rookeries are in italics and denoted with a ●. Regional codes are as in Fig. 1.

Next, F - and Φ -statistics were generated at the stock level. Kamchatka Peninsula, Kuril Islands, and Sea of Okhotsk were placed in the Asian stock. The Commander Islands, western Aleutian Islands, central Aleutian Islands, eastern Aleutian Islands, Bering Sea, western Gulf of Alaska, central Gulf of Alaska, and Prince William Sound were placed in the western stock. The rookeries in southeastern Alaska, British Columbia, Oregon, and northern California comprised the eastern stock. All pairwise comparisons yielded highly significant ($P \leq 0.001$) F_{st} values of 0.0838 (Asian–western), 0.0887 (western–eastern), and 0.0463 (Asian–eastern). A neighbor-joining tree constructed from these values showed the Asian and eastern stocks to be sister groups. All 3 Φ_{st} values also were significant (Asian–western = 0.0809, Asian–eastern = 0.241, western–eastern = 0.339; $P \leq 0.001$). A neighbor-joining tree constructed from these Φ_{st} estimates showed Asian and western stocks to be sister groups.

The test for isolation by distance revealed no significant linear correlation between geographic distances and genetic distances (F_{st} and Φ_{st} values) at the rookery level. In fact, the null hypothesis (random distribution of data points with no linear correlation between genetic and geographic distances) was supported by the data ($P \leq 0.0001$). However, when comparisons were restricted to rookeries of the same stock, all tests revealed significant linear correlation except one. The Asian stock rookeries showed no significant correlation between F_{st} and geographic distance (support for H_0 , $P \leq 0.05$). However, there was a significant correlation between Φ_{st} estimates and geographic distance for the Asian stock rookeries. The analysis also was performed on the combined western stock and Asian stock rookeries. No significant correlation between geographic distance and genetic distance was observed for either F_{st} or Φ_{st} estimates.

Maximum-likelihood estimates of migration rates were next obtained by using the program MIGRATE. Given the F_{st} and Φ_{st} results provided above, 3 populations (Asian, western, and eastern stocks) were assumed. Migration rates between stocks (number of effective female migrants per generation, N_{fm}) were as follows: western to Asian 95% confidence interval (CI) of 11.5–18.9 with a best estimate of 14.8, Asian to western 95% CI of 11.7–18.0 with a best estimate of 14.6, eastern to Asian 95% CI of 0.133–0.854 with a best estimate of 0.177, Asian to eastern 95% CI of 1.01–4.36 with a best estimate of 2.72, eastern to western 95% CI of 0.756–2.73 with a best estimate of 1.54, and western to eastern 95% CI of 1.66–5.32 with a best estimate of 3.19. Thus, there was an average migrant exchange of 14.7 females per generation between the Asian and western stocks, 1.45 females per generation between the eastern and Asian stocks, and 2.37 females per generation between the western and eastern stocks.

Migration rates between stocks were also calculated from F - and Φ -statistics. The number of female migrants per generation estimated from F -statistics was 5.97 between the Asian and western stocks, 10.8 between the Asian and eastern stocks, and 5.64 between the eastern and western stocks. Likewise, the number of female migrants estimated from Φ -statistics was 6.18 between the Asian and western stocks, 2.07 between the

Asian and eastern stocks, and 1.48 between the eastern and western stocks.

DISCUSSION

Mitochondrial DNA diversity.—To date, 145 haplotypes have been reported for a 238-bp segment of the Steller sea lion mitochondrial control region. Of these, 121 were found in pups sampled at their natal rookery and the rest have only been observed in scats or in juveniles or adults sampled away from their rookery. It is reasonable to assume that more haplotypes will be identified as sample sizes increase. Thus, the high haplotypic diversity observed range-wide ($H = 0.916 \pm 0.004$) was expected, and a similar degree of diversity has been reported for the mitochondrial control region of other marine mammals, including harbor seals (*Phoca vitulina*; $H = 0.975$ —Westlake and O’Corry-Crowe 2002) and Dall’s porpoise (*Phocoenoides dalli*; $H = 0.96$ —Escorza-Trevino and Dizon 2000). Previous reports for haplotype (gene) diversity for various rookeries and regions in Steller sea lions were similar to those found here (Bickham et al. 1996, 1998a, 1998b). Furthermore, the moderate nucleotide diversity observed ($\pi = 0.0097 \pm 0.0060$) is consistent with the vast majority of haplotypes differing by a single substitution event from 1 or more haplotypes. Despite the recent decline in numbers of Steller sea lions, mtDNA haplotype diversity does not seem to have been appreciably reduced. The L-shaped distribution of haplotype frequencies provides strong evidence for an absence of bottleneck effects on haplotype diversity (Luikart et al. 1998). Likewise, the high range-wide haplotype diversity estimate is comparable to that of other marine mammals (cetaceans) that have not experienced a bottleneck (Rooney et al. 2001). Nucleotide diversity in Steller sea lions is intermediate between whale populations that have had bottlenecks and those that have not (Rooney et al. 2001).

Phylogeography.—Only 2 haplotypes occurred at a frequency $> 10\%$, including S (18.2%) and BB (15.9%). Two haplotypes (A and BB) were distributed throughout the entire species range, whereas most were restricted to certain regions. For example, haplotypes LLL, E, and H were completely or nearly restricted to the Asian, western, and eastern stocks, respectively (Fig. 2). The geographic partitioning of various haplotypes resulted in definite patterns of population subdivision at both the rookery and region levels. Despite the generally high sample size in this study, resolution of population substructure increased when rookeries were grouped into their respective regions. One possible reason for this is a sample-size effect. Eastern stock rookeries were clearly differentiated from all other rookeries when using Φ -statistics (Fig. 3B) but less clearly differentiated when conventional F -statistics were applied (Fig. 3A). The neighbor-joining tree constructed at the regional level by using F -statistics (Fig. 4A) resolved 3 distinct lineages, whereas the tree constructed from Φ -statistics (Fig. 4B) resolved only 2 separate lineages, although Asian regions clearly occupied the most basal positions and were genetically differentiated from all other groups.

All analyses placed Medny Island, the only rookery of the Commander Islands, with Alaskan western stock rookeries rather than with Asian rookeries. These results do not support the conclusions of Trujillo et al. (2004), who suggested that the Medny Island population was more closely related to the other Russian rookeries. A similar break between Russian populations, including Medny Island, and Aleutian Island populations has been reported for sea otters (*Enhydra lutris*—Cronin et al. 1996) and harbor seals (Westlake and O’Corry-Crowe 2002). So, our present findings regarding the relationships of the Medny Island population were surprising. F_{st} estimates were good at isolating the western stock from the eastern stock and from the Asian rookeries (Fig. 3A). This analysis shows Medny Island to be part of the western stock. Because this rookery is of recent origin, beginning in 1972 (Mamaev and Burkanov 1996; Muzhchinkin 1964), it is clear that it must have been founded by immigrants from the Aleutian Islands, not from Asian rookeries. This arrangement is supported in all assessments of rookeries and regions (Figs. 3 and 4). The present study includes a much larger sample size from Medny Island ($n = 106$) than was available to Trujillo et al. (2004; $n = 10$). This increased sample size provides a more accurate assessment of the Medny Island rookery’s phylogeographic associations.

Given the F_{st} and Φ_{st} results obtained at the rookery and region levels, 3 populations were assumed for analyses of stock structure, the Asian, western, and eastern stocks. All F_{st} and Φ_{st} values were significant, supporting the recognition of 3 stocks, although the relationships between stocks differed between analyses. Thus, the currently recognized eastern stock should not be altered, but the western stock should be partitioned west of the Commander Islands (165°E), yielding a western stock that ranges from Prince William Sound west to the Commander Islands, and an Asian stock including rookeries from the Kamchatka Peninsula, Kuril Islands, and Sea of Okhotsk (Fig. 1).

Analyses of isolation by distance indicated significant linear correlations between measures of genetic distance and geographic distance among rookeries (with 1 exception), but only when rookeries within stocks are considered. These results support the partitioning of the range of Steller sea lions into 3 genetically differentiated stocks, each of which contains a number of populations (rookeries) that follow an isolation by distance model of population subdivision. The zones of contact between the Asian and western stocks and between the eastern and western stocks likely do not represent barriers to gene flow. Rather, they are the historical points of contact of 3 expanding populations that have adjusted their ranges in response to increased habitat availability since the last glaciation.

Inter- and intrastock patterns of migration.—Maximum-likelihood estimation of $N_f m$ revealed a level of migrant exchange between the western and Asian stocks that was roughly 10 times the rate of exchange between the Asian and eastern stocks and approximately 6-fold greater than the exchange between the western and eastern stocks. The moderate levels of mitochondrial gene flow occurring between Asian and eastern and especially between western and eastern stocks explain the distinct differentiation of eastern stock rookeries and regions observed in the F_{st} and Φ_{st} analyses. In fact, all

interstock migration rates were generally low, which is consistent with the relatively high degree of natal site fidelity thought to characterize this species. It is likely that female interchange among rookeries within regions is relatively high, at least over evolutionary timescales. This can be inferred from the fact that the neighbor-joining trees of rookeries show relatively little concordance with geographic distribution (Fig. 3). However, neighbor-joining trees based on regions tend to reflect more precisely the geographic distributions. Arrangements of the regions based on F_{st} estimates precisely reflect their geographic relationships within both the Asian and eastern stocks (Fig. 4). Among the western stock regions, the relationship is not quite perfect but the most westerly regions (Commander Islands, western Aleutian Islands, and central Aleutian Islands) are the most basal and the easternmost regions form a tight cluster at the tip. It is also apparent that western stock regions (particularly eastern Aleutian Islands, Bering Sea, western Gulf of Alaska, central Gulf of Alaska, and Prince William Sound) generally show shorter branch lengths than do the eastern stock and Asian stock regions (Fig. 4A). This likely reflects high exchange of migrants among the rookeries of the easternmost western stock regions (from Prince William Sound to the eastern Aleutian Islands and the Bering Sea). There are notable differences between the trees obtained from the F_{st} and Φ_{st} analyses (Figs. 4A and 4B). Support for recognition of an Asian stock is clearly more pronounced in the F_{st} tree (Fig. 4A). This infers that haplotype frequencies are more important than sequence in separating the Asian stock. This contrasts with the high level of differentiation observed for the eastern stock in both F_{st} and Φ_{st} analyses (Fig. 4). The most likely reason for this pattern is that the eastern stock haplotypes form relatively deeply branched networks, whereas the haplotypes characteristic of the Asian stock are more recently evolved and do not form such networks. This can be seen in the haplotype trees presented in earlier studies of this species (Bickham et al. 1996, 1998b).

Estimates of migrant exchange obtained from F_{st} and Φ_{st} analyses in some cases differed significantly from maximum-likelihood estimates. For instance, the average of the maximum-likelihood estimates of female migrants exchanged between the Asian stock and the western stock was at least twice as high as the rates obtained from both F_{st} and Φ_{st} estimates. However, the values estimated from Φ -statistics for the Asian–eastern and western–eastern migrant exchange were similar to maximum-likelihood estimates, whereas the rates of exchange estimated from F -statistics were unlike those obtained when using either the maximum-likelihood approach or those estimated from Φ -statistics. Obviously, more modeling is needed to determine which approach is best for estimation of migration rates. Still, maximum-likelihood estimates appear to be the most logical, indicating that the highest levels of gene flow are occurring between the Asian and western stocks and low levels of exchange are occurring between the eastern stock and both the western and Asian stocks.

Patterns of population subdivision (stock structure) result from historical processes, mutation, genetic drift, and current patterns of migration (Avise 1994). The high degree of

differentiation of the eastern stock likely reflects some or all of these processes. The eastern stock haplotypes form a well-differentiated network in phylogenetic analyses, which might explain why the estimates of Φ_{st} show longer branch lengths leading to the eastern stock regions (Fig. 4B). The eastern stock is also well differentiated by F_{st} estimates (Fig. 4A). It was suggested that the eastern stock likely differentiated from the western stock as a result of isolation in different Pleistocene glacial refugia (Bickham et al. 1996). The fact that 2 other species of marine mammals, harbor seals (Westlake and O'Corry-Crowe 2002) and sea otters (Cronin et al. 1996), show a major break between populations east and west of 144°W longitude supports this conclusion. Such genealogical concordance involving shared phylogeographic patterns among unrelated species with similar distributions is presumably the result of similar historic influences on the intraspecific genetic architecture (Avise 1994). Likewise, sockeye salmon (*Onchorhynchus nerka*), which have a similar distribution to that of Steller sea lions, are hypothesized to have been isolated in Pleistocene glacial refugia in Beringia and the Pacific Northwest (Columbia River—Lindsey and McPhail 1986; McPhail and Lindsey 1970, 1986). The differentiation of the southernmost populations, presumably descended from the Pacific Northwest refugium, and the northern populations, presumably from the Beringian refugium, was well supported by allozyme and mtDNA data (Bickham et al. 1995).

CONCLUSIONS

Mitochondrial DNA analysis supports the recognition of 3 stocks, the Asian, western, and eastern stocks, in Steller sea lions. Medny Island, the only rookery of the Commander Island chain, is placed within the western stock, rather than within the Asian stock. Generally, moderate rates of migration were estimated among stocks. Higher rates of migrant exchange were estimated between the Asian and western stocks than between the eastern and western stocks. This is consistent with the conclusion that the major phylogeographic break within the species is between the eastern and western stocks. Estimates of population subdivision based on F_{st} and Φ_{st} statistics at the rookery and region levels support the 3-stock hypothesis, as do patterns of among-stock migration and isolation by distance.

ACKNOWLEDGMENTS

We thank the many people involved in collecting the tissues used in this study, especially Thomas Gelatt, Ken Pitcher, Eugenie Mamaev, Nikolay Pavlov, Vladimir Vertjankin, and Sergey Zadal'sky. We thank Rodney L. Honeycutt and J. Spencer Johnston for reviewing earlier drafts of this manuscript. Ryan Huebinger provided laboratory and analytical assistance. Funding for the laboratory analyses was provided by National Marine Fisheries Service. Funding for fieldwork was provided by the National Marine Fisheries Service, Alaska Department of Fish and Game, and the Alaska Sea Life Center.

LITERATURE CITED

ALLEN, J. A. 1870. On the eared seals (Otariidae) with detailed descriptions of the North Pacific species. *Bulletin of the Museum of Comparative Zoology at Harvard College* 2:1–89.

- AMOS, B., AND A. R. HOELZEL. 1991. Long-term preservation of whale skin for DNA analysis. Report of the International Whaling Commission Special Issue 13:99–103.
- ANIMAL CARE AND USE COMMITTEE. 1998. Guidelines for the capture, handling, and care of mammals as approved by the American Society of Mammalogists. *Journal of Mammalogy* 79:1416–1431.
- AVISE, J. C. 1994. Molecular markers, natural history and evolution. Chapman & Hall, New York.
- BICKHAM, J. W., T. R. LOUGHLIN, D. G. CALKINS, J. K. WICKLIFFE, AND J. C. PATTON. 1998a. Genetic variability and population decline in Steller sea lions from the Gulf of Alaska. *Journal of Mammalogy* 79:1390–1395.
- BICKHAM, J. W., T. R. LOUGHLIN, J. K. WICKLIFFE, AND V. N. BURKANOV. 1998b. Geographic variation in the mitochondrial DNA of Steller sea lions: haplotype diversity and endemism in the Kuril Islands. *Biosphere Conservation* 1:107–117.
- BICKHAM, J. W., J. C. PATTON, AND T. R. LOUGHLIN. 1996. High variability for control-region sequences in a marine mammal: implications for conservation and biogeography of Steller sea lions (*Eumetopias jubatus*). *Journal of Mammalogy* 77:95–108.
- BICKHAM, J. W., C. C. WOOD, AND J. C. PATTON. 1995. Variation in mitochondrial cytochrome *b* sequences and allozymes in sockeye (*Onchorhynchus nerka*). *Journal of Heredity* 86:140–144.
- CRONIN, M. A., J. BODKIN, B. BALLACHEY, J. ESTES, AND J. C. PATTON. 1996. Mitochondrial-DNA variation among subspecies and populations of sea otters (*Enhydra lutris*). *Journal of Mammalogy* 77:546–557.
- ESCORZA-TREVINO, S., AND A. E. DIZON. 2000. Phylogeography, intraspecific structure and sex-biased dispersal of Dall's porpoise, *Phocoenoides dalli*, revealed by mitochondrial and microsatellite DNA analyses. *Molecular Ecology* 9:1049–1060.
- EXCOFFIER, L., P. E. SMOUSE, AND J. M. QUATTRO. 1992. Analysis of molecular variance inferred from metric distances among DNA haplotypes: application to human mitochondrial DNA restriction data. *Genetics* 131:479–491.
- GENTRY, R. L., AND D. E. WITHROW. 1986. Steller sea lion. Pp. 188–194 in *Marine mammals* (D. Haley, ed.). 2nd ed. Pacific Search Press, Seattle, Washington.
- HARTL, D. L., AND A. G. CLARK. 1997. Principles of population genetics. 3rd ed. Sinauer Associates, Inc., Publishers, Sunderland, Massachusetts.
- HEDRICK, P. W. 2000. Genetics of populations. 2nd ed. Jones and Bartlett Publishers, Inc., Sudbury, Massachusetts.
- KENYON, K. W., AND D. W. RICE. 1961. Abundance and distribution of the Steller sea lion. *Journal of Mammalogy* 42:223–234.
- LIDICKER, W. Z., JR., R. D. SAGE, AND D. G. CALKINS. 1981. Biochemical variation in northern sea lions from Alaska. Pp. 231–244 in *Mammalian population genetics* (M. H. Smith and J. Joule, eds.). University of Georgia Press, Athens.
- LINDSEY, C. C., AND J. D. MCPHAIL. 1986. Zoogeography of fishes of the Yukon and Mackenzie basins. Pp. 639–674 in *Zoogeography of North American freshwater fishes* (C. W. Hocutt and E. O. Wiley, eds.). Wiley, New York.
- LOUGHLIN, T. R. 1997. Using the phylogeographic method to identify Steller sea lion stocks. Pp. 159–171 in *Molecular genetics of marine mammals* (A. Dizon, S. J. Chivers, and W. F. Perrin, eds.). Special Publication 3, Society of Marine Mammalogy.
- LOUGHLIN, T. R. 1998. The Steller sea lion: a declining species. *Biosphere Conservation* 1:91–98.
- LOUGHLIN, T. R., A. S. PERLOV, AND V. A. VLADIMIROV. 1984. Northern sea lion distribution and abundance: 1956–1980. *Journal of Wildlife Management* 48:729–740.

- LOUGHLIN, T. R., A. S. PERLOV, AND V. A. VLADIMIROV. 1992. Range-wide survey and estimation of total number of Steller sea lions in 1989. *Marine Mammal Science* 8:220–239.
- LOUGHLIN, T. R., AND A. E. YORK. 2000. An accounting of the sources of Steller sea lion, *Eumetopias jubatus*, mortality. *Marine Fisheries Review* 62:40–45.
- LUIKART, G., F. W. ALLENDORF, J. M. CORNUET, AND W. B. SHERWIN. 1998. Distortion of allele frequency distributions provides a test for recent population bottlenecks. *Journal of Heredity* 89:238–247.
- MAMAEV, E. G., AND V. N. BURKANOV. 1996. Sostoyanie reproductivnoy gruppировки civuchey *Eumetopias jubatus* (Pinnipedia, Otariidae) na Yugo-Vostochnom lezhbishche ostrova Medny (Komandorskie ostrova) [Condition of reproductive group of Steller sea lions *Eumetopias jubatus* (Pinnipedia, Otariidae) on the southeastern rookery of Medny Island (Commander Islands)]. *Izvestiya TINRO* 121:163–165.
- MANIATIS, T. E., E. F. FRISTCH, AND J. SAMBROOK. 1982. *Molecular cloning: a laboratory manual*. Cold Spring Harbor Publications, Cold Spring Harbor, New York.
- MANTEL, N. 1967. The detection of disease clustering and generalized regression approach. *Cancer Research* 27:209–220.
- McPHAIL, J. D., AND C. C. LINDSEY. 1970. Freshwater fishes of northwestern Canada and Alaska. *Bulletin of the Fisheries Research Board of Canada* 173:1–381.
- McPHAIL, J. D., AND C. C. LINDSEY. 1986. Zoogeography of freshwater fishes of Cascadia (the Columbia system and rivers north to the Stikine). Pp. 615–637 in *Zoogeography of North American freshwater fishes* (C. W. Hocutt and E. O. Wiley, eds.). Wiley, New York.
- MUZHCHINKIN, V. F. 1964. Raspredelenie sivuchey na Yugo-Vostochnom kotikovom lezhbishche ostrova Medny [Steller sea lion distribution at Yugo-Vostochnoe (south-east) fur seal rookery of Medny Island]. *Izvestiya TINRO* 54:179–186.
- NATIONAL MARINE MAMMAL LABORATORY. 1995. Status review of the United States Steller sea lion (*Eumetopias jubatus*) populations. National Marine Mammal Laboratory, National Marine Fisheries Service, Report pp. 1–61.
- NEI, M. 1987. *Molecular evolutionary genetics*. Columbia University Press, New York.
- RAYMOND, M., AND F. ROUSSET. 1995. An exact test for population differentiation. *Evolution* 49:1280–1283.
- ROONEY, A. P., R. L. HONEYCUTT, AND J. N. DERR. 2001. Historical population size change of bowhead whales inferred from DNA sequence polymorphism data. *Evolution* 55:1678–1685.
- SEASE, J. L., AND C. J. GUDMUNDSON. 2002. Aerial and land-based surveys of Steller sea lions (*Eumetopias jubatus*) from the western stock in Alaska, June and July 2001 and 2002. United States Department of Commerce, National Oceanic and Atmospheric Administration, National Marine Fisheries Service, Alaska Fisheries Science Center, Technical Memorandum 131:1–45.
- SEASE, J. L., W. P. TAYLOR, T. R. LOUGHLIN, AND K. W. PITCHER. 2001. Aerial and land-based surveys of Steller sea lions (*Eumetopias jubatus*) in Alaska, June and July 1999 and 2000. United States Department of Commerce, National Oceanic and Atmospheric Administration, National Marine Fisheries Service, Alaska Fisheries Science Center, Technical Memorandum 122:1–52.
- SLATKIN, M. 1995. A measure of population subdivision based on microsatellite allele frequencies. *Genetics* 139:457–462.
- SWOFFORD, D. L. 1998. PAUP*. Phylogenetic analysis using parsimony (*and other methods). Version 4. Sinauer Associates, Inc., Publishers, Sunderland, Massachusetts.
- TAMURA, L., AND M. NEI. 1993. Estimation of the number of nucleotide substitutions in the control region of mitochondrial DNA in humans and chimpanzees. *Molecular Biology and Evolution* 10:512–526.
- TRUJILLO, R. G., T. R. LOUGHLIN, N. J. GEMMELL, J. C. PATTON, AND J. W. BICKHAM. 2004. Variation in microsatellites and mtDNA across the range of the Steller sea lion, *Eumetopias jubatus*. *Journal of Mammalogy* 85:12–20.
- WESTLAKE, R. L., AND G. M. O'CORRY-CROWE. 2002. Macrogeographic structure and patterns of genetic diversity in harbor seals (*Phoca vitulina*) from Alaska to Japan. *Journal of Mammalogy* 83:1111–1126.
- WRIGHT, S. 1951. The genetical structure of populations. *Annals of Eugenics* 15:323–354.
- YORK, A. E. 1994. The population dynamics of northern sea lions, 1975–1985. *Marine Mammal Science* 10:38–51.

Submitted 28 September 2004. Accepted 6 April 2005.

Associate Editor was Enrique P. Lessa.

APPENDIX I

Stocks, regions, rookeries, and sample sizes.—The 1,568 tissue samples used in this study are from pups taken at their natal rookeries. Rookeries are numbered as in Fig. 1. Sample sizes (n) are given for stocks, regions within stocks, and rookeries within regions.

Asian stock $n = 426$. Sea of Okhotsk $n = 148$; 1 Iony Island $n = 100$; 2 Yamsky Island $n = 48$. Kuril Islands $n = 207$; 3 Chernye Brat'ya $n = 31$; 4 Srednego Island $n = 41$; 5 Raykoke Island $n = 51$; 6 Lovushki Island $n = 39$; 7 Antsiferova Island $n = 45$. Kamchatka Peninsula $n = 71$; 8 Zheleznaya Bay $n = 12$; 9 Kozlova Cape $n = 59$.

Western stock $n = 958$. Commander Islands $n = 106$; 10 Medny Island $n = 106$. Western Aleutian Islands $n = 55$; 11 Attu Island $n = 10$; 12 Agattu Island $n = 25$; 13 Buldir Island $n = 20$. Central Aleutian Islands $n = 193$; 14 Kiska Island, Cape St. Stephen $n = 47$; 15 Kiska Island, Lief Cove $n = 46$; 16 Amchitka Island $n = 10$; 17 Ulak Island $n = 9$; 18 Gramp Rock $n = 10$; 19 Kasatoshi Island $n = 10$; 20 Seguam Island $n = 31$; 21 Yunaska Island $n = 30$. Eastern Aleutian Islands $n = 237$; 22 Adugak Island $n = 10$; 23 Ogchul Island $n = 10$; 24 Bogoslof Island $n = 11$; 25 Akutan Island $n = 85$; 26 Akun Island $n = 13$; 27 Ugamak Island $n = 99$; 28 Amak Island $n = 9$. Bering Sea $n = 22$; 29 Walrus Island $n = 22$. Western Gulf of Alaska $n = 99$; 30 Clubbing Rocks $n = 26$; 31 Pinnacle Rock $n = 30$; 32 The Whaleback $n = 2$; 33 Chernabura Island $n = 5$; 34 Atkins Island $n = 36$. Central Gulf of Alaska $n = 119$; 35 Chowiet Island $n = 10$; 36 Chirikof Island $n = 31$; 37 Marmot Island $n = 50$; 38 Latax Rocks $n = 1$; 39 Sugarloaf Island $n = 21$; 40 Chiswell Island $n = 6$. Prince William Sound $n = 127$; 41 Fish Island $n = 47$; 42 Seal Rocks $n = 77$; 43 Cape St. Elias $n = 3$.

Eastern stock $n = 184$. Southeastern Alaska $n = 68$; 44 White Sisters Island $n = 20$; 45 Hazy Island $n = 37$; 46 Forrester Island $n = 11$. British Columbia $n = 23$; 47 North Danger Rocks $n = 10$; 48 Triangle Island $n = 13$. Oregon $n = 83$; 49 Rogue Reef $n = 83$. Northern California $n = 10$; 50 St. George Reef $n = 10$.